

## Hitch, 2" Receiver, Jeep Wrangler

### INSTALLATION INSTRUCTIONS

**READ ALL WARNINGS AND INSTRUCTIONS BEFORE INSTALLATION**

**⚠️WARNING:** Never exceed the vehicle manufacturer's recommended towing capacity.

**NOTICE:**

- Always use proper tools and safety equipment to ensure a safe and quality installation.
- Inspection of the trailer hitch should be performed before and after each use to ensure all mounting hardware is tight and related hitch components are secure.

**⚠️WARNING:** Before you begin installation, read all instructions thoroughly.

**⚠️WARNING:** Safety glasses should be worn at all times while installing this product.

**⚠️WARNING:** Failure to adhere to exact torque specifications when securing hardware during the installation process can result in damage to the product or your vehicle. This will void the hitch warranty.

**LEVEL OF DIFFICULTY:** Easy

Installation difficulty levels are based on time and effort required. They will vary depending on the installer's expertise. Vehicle condition could be a factor in the level of difficulty for a proper installation.

**WEIGHT CARRYING CAPACITY**

Gross Trailer Weight (GTW)	3,500 lb
Tongue Weight (TW)	350 lb

**WEIGHT DISTRIBUTION CAPACITY**

Weight Distribution (WD)	4,000 lb
WD Tongue Weight (WDTW)	400 lb

**PARTS LIST**

Item	Qty	Description
1	4	HHCS, 1/2-13 UNC, 4-1/2, GRD8, YZ
2	4	Washer, Flat, 1/2, YZ
3	4	Nut, Ser-Flange, 1/2-13 UNC, GRD8, YZ

**TOOLS REQUIRED**

Safety Glasses
Ratchet
3/4" Socket
Torque Wrench
Die Grinder

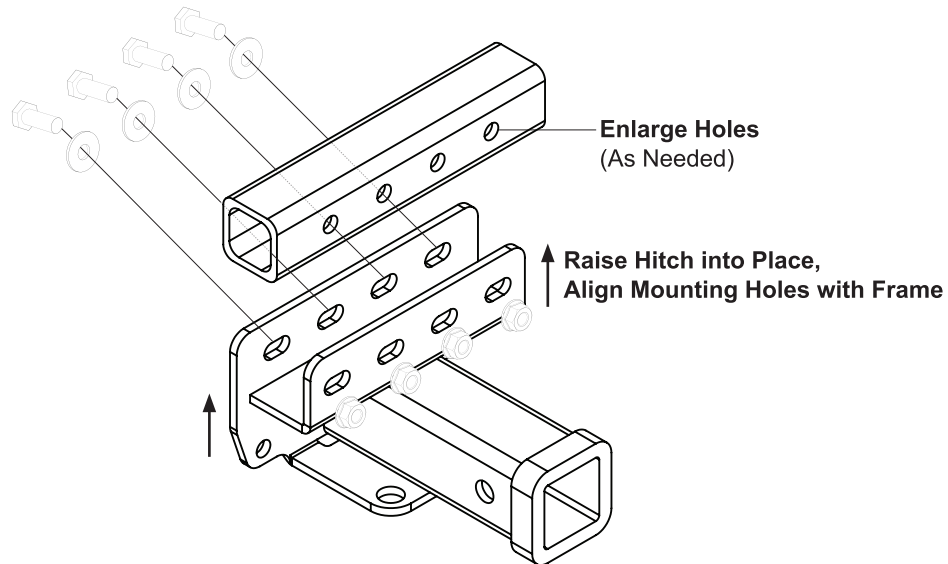

#### INSTALLATION:

1. Detach the muffler from the rubber muffler hanger and lower the exhaust for easier installation.
2. Place the hitch over the bumper beam and align the holes of the hitch with holes in the cross beam.  
**Note:** Some models may have existing bolts attached to a plate with weld nuts. The hitch will need to be slid in between the bracket and the mounting tube with the factory hardware reinstalled, securing the hitch.
3. Insert the fasteners as shown making sure the flange nuts are installed on the exterior side of the hitch. Some models may require hole enlargement.
4. Torque all 1/2" fasteners to 110 lb-ft.

IF YOU EXPERIENCE ANY PROBLEMS WITH YOUR TOWSMART PRODUCT, DO NOT RETURN THE UNIT TO THE RETAILER FROM WHICH IT WAS PURCHASED. INSTEAD, PLEASE CALL 1-844-295-9215 FOR ASSISTANCE WITH ANY PROBLEMS. WARRANTY INFORMATION IS AVAILABLE UPON REQUEST AND CAN BE FOUND ONLINE AT TOWSMART.COM.

©08/2023



**CUSTOM**

A Winston Products Company  
TOWSMART.COM  
WINSTON PRODUCTS, LLC.  
30339 Diamond Parkway  
Cleveland, OH 44139