

**TOWSMART Part Number: 2058**

ORIS Part Number: 200704

Instrucciones de montaje — Instruction de montage — Fitting instruction

## Volvo XC60

03/2017 -



Not Visible



motion sensor  
trunk release

Hybrid

R-design

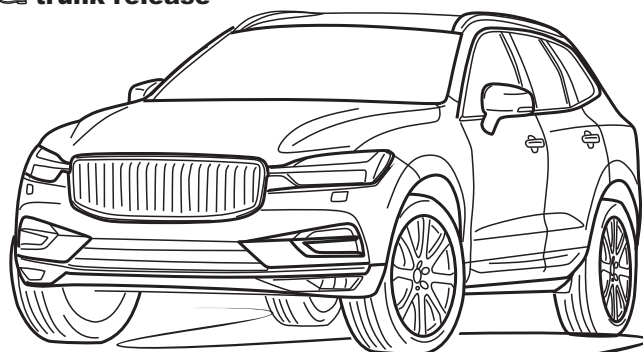

## Volvo XC90

09/2014 -



Not Visible



motion sensor  
trunk release

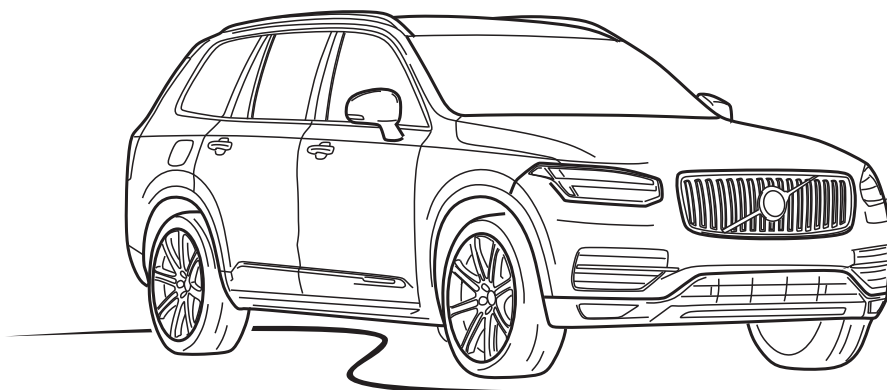

Check our webpage for the latest and the full-color copy of this fitting instruction.

[www.oris-automotive.com/en/](http://www.oris-automotive.com/en/)

Version: 05  
Date: 04-09-2024



**THESE INSTRUCTIONS MUST BE GIVEN TO THE END USER**

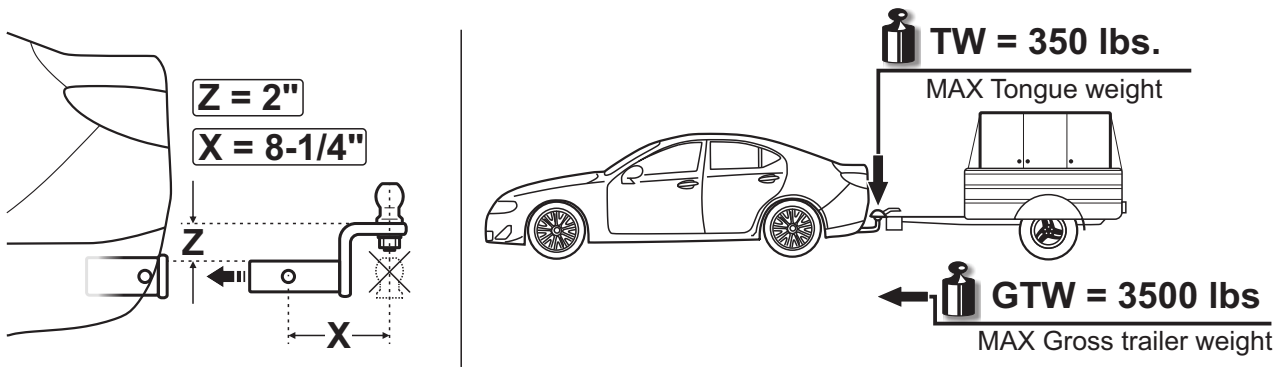

**Never exceed the vehicle or the hitch manufacturer's recommended towing capacity and tongue weight.**



### **IMPORTANT SAFETY NOTICE FOR HITCH INSTALLERS AND CUSTOMERS**

Read all installation, operating and safety instructions along with all labels before installing or using this product. Failure to comply with the safety information could result in serious injury or death.



[www.oris-automotive.com/en/safety/](http://www.oris-automotive.com/en/safety/)



**WARNING:** This product can expose you to chemicals including carbon black, which is known to the State of California to cause cancer. For more information go to [www.P65Warnings.ca.gov](http://www.P65Warnings.ca.gov)



**WARNING:** Do not perform any installation or towing procedures without fully understanding the correct tools and actions for all steps. Call for support if needed.



[www.oris-automotive.com/en/acps-automotive-aftermarket-worldwide/](http://www.oris-automotive.com/en/acps-automotive-aftermarket-worldwide/)

## Legend / Légende / Leyenda



US Attention  
F Attention  
E Atención



US Incorrect  
F Incorrect  
E Incorrecto



US Correct  
F Correct  
E Correcto



US Inspect  
F Examiner  
E Revise



US In both sides  
F Tous les deux côtés  
E En ambos lados



US Manually  
F À la main  
E A mano



US Only 2 persons may carry out  
F Toujours s'y mettre de deux  
E Operación que requiere dos personas



US Remove  
F Rebuter  
E Tratamiento de residuos



US Location/Position Arrow  
F Flèche de Position  
E Flecha de posición



US Movement Arrow  
F Flèche de mouvement  
E Flecha de movimiento



US Protect it against corrosion  
F Protéger contre la corrosion  
E Proteger contra la corrosión



US Electrical connection  
F Connexion électrique  
E Conexión eléctrica

## Tools Required / Outils requis / Herramientas requeridas

15

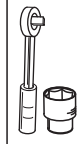

RATCHET WITH SOCKET



CUTTING TOOL



PLASTIC PRY

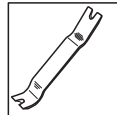

TORQUE WRENCH WITH SOCKET 10, 17



PLIERS

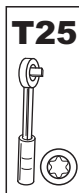

TORX

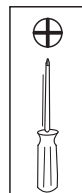

PHILLIS HEAD SCREWDRIVER

## Safety / Sécurité / Seguridad

Should be worn at all times while installing this product.

Il doit être porté en permanence lors de l'installation de ce produit.

Debe llevarse en todo momento mientras se instala este producto.



# Assembly / Assemblage / Montaje

Mounting time

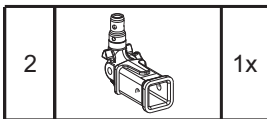
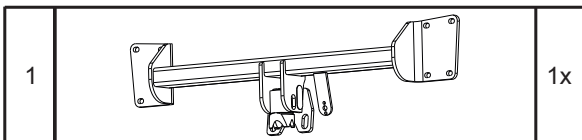
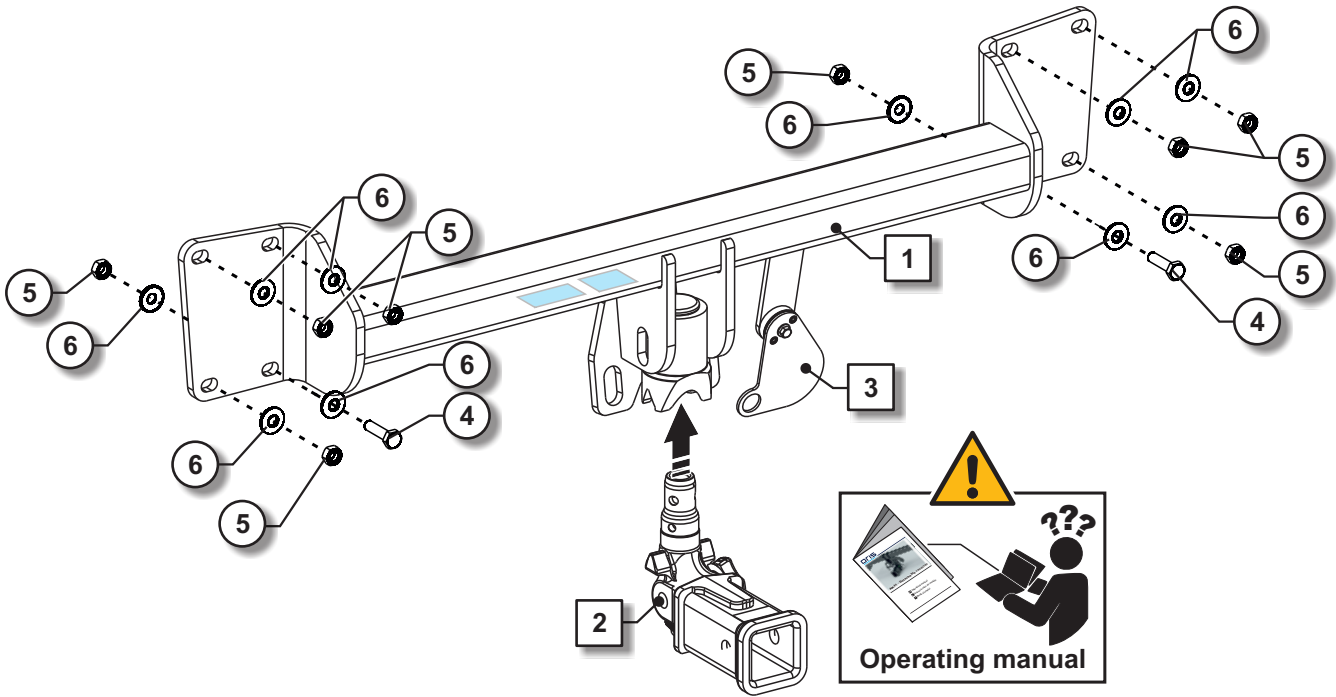
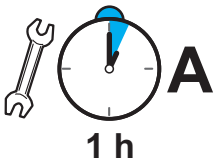

4		M10x40	DIN933	10.9	2x	50lbs-ft
5		M10	DIN934	10	8x	
6		10x27x2,8	NFE25510		10x	

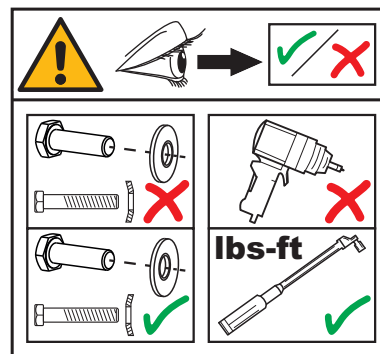

Spare Parts

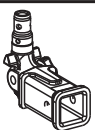

290019



290029

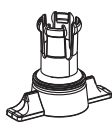

290039



290059

**1**

**A. Remove 2 trunk bump stops, 1 on each side**

**2**

**A. Remove 6 T25 screws in wheel liner**

**3**

**B. Remove 1 T25 more screw behind wheel liner attaching the bumper to frame**

**4**

**A. Remove 2 T25 screws under center of the bumper**

**5**

**A. Remove 2 panels next to tail light using a trim tool**  
**B. Remove 2 8mm bolts**

XC60  
 XC90

**6**

**B. Remove bumper and disconnect Wire harness**

**7**

**A.** Remove 6 15mm nuts holding bumper beam in place  
**B.** Scrap bumper beam

**8**

**A.** Put on hitch

**9**

**A.** Install tow bar using supplied hardware and tighten to 50 lbs-ft

**10**

**A.** Assemble socket plate as shown in picture and tighten to specifications provided (optional socket plate for wiring harness)

**11**

**A.** Cut out heat shield as shown in picture using tool of choice

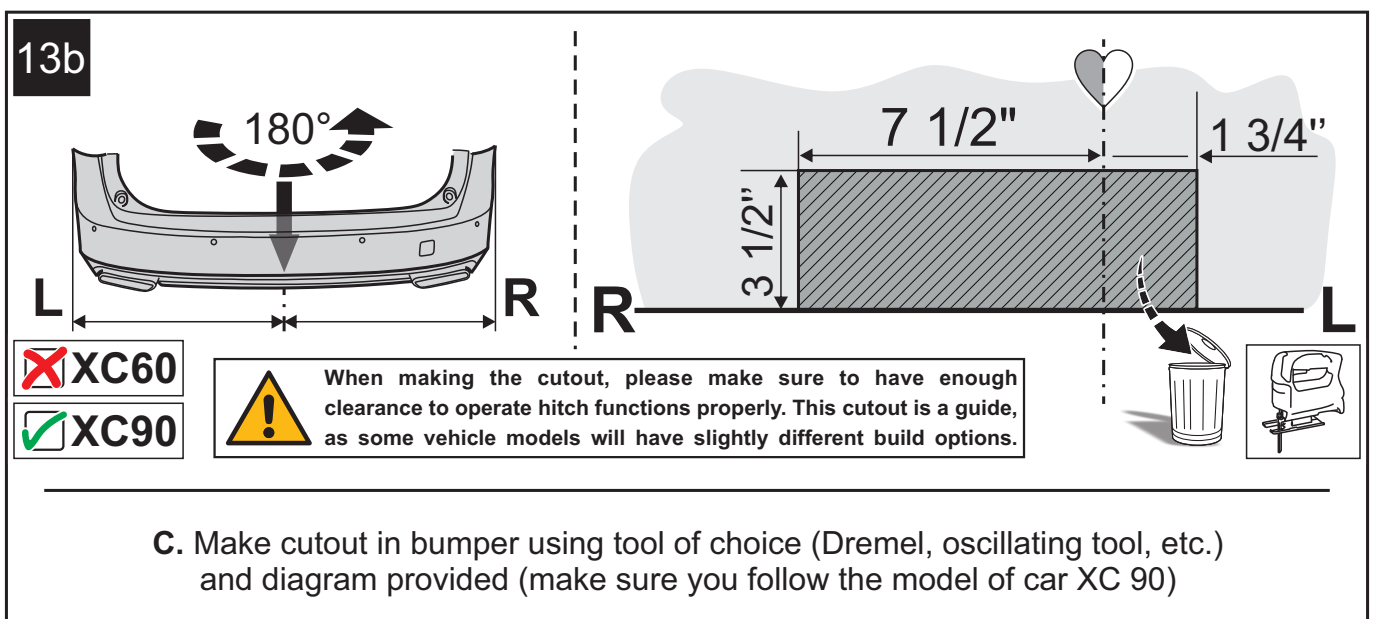
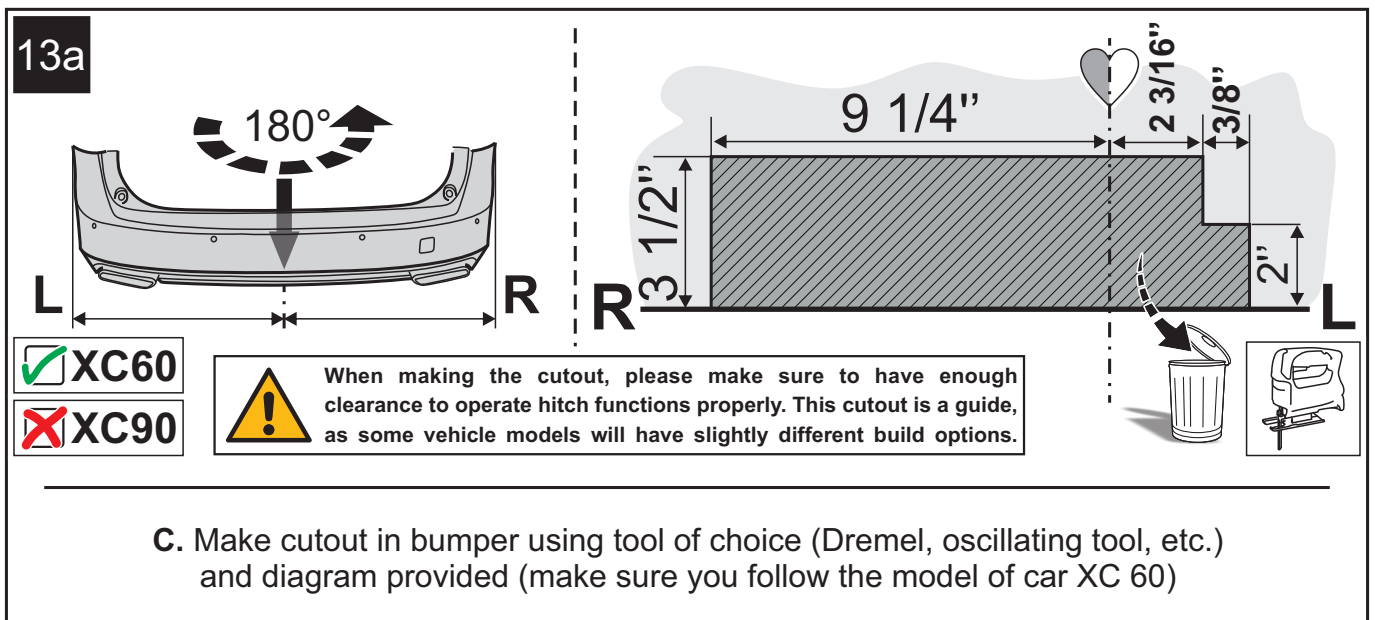
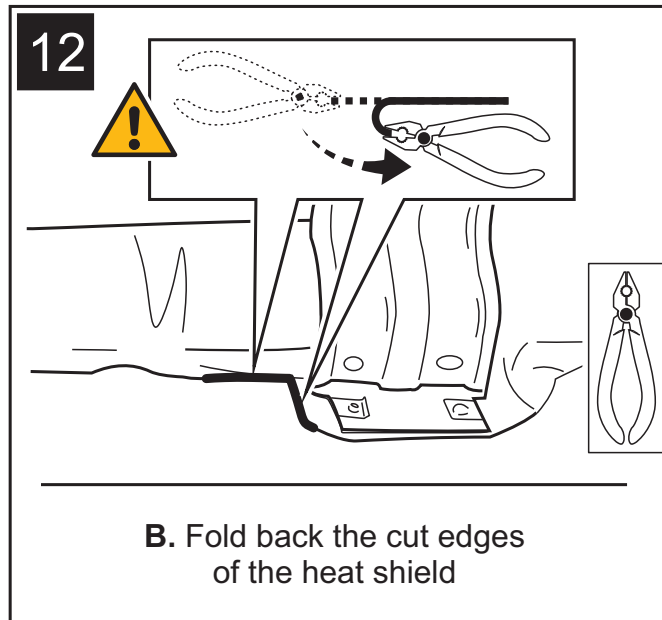

**14**

**A. Reattach bumper in the reverse order it was taken off**

**15**

**A. Reattach 2 8mm bolts**  
**B. Reattach 2 panels next to tail light**

✓ XC60  
 ✗ XC90

**16**

**A. Reattach 2 T25 screws under center of the bumper**

**17**

**A. Reattach 1 T25 more screw behind wheel liner attaching the bumper to frame**

**18**

**B. Reattach 6 T25 screws in wheel liner**

**19**

**A. Reattach 2 trunk bump stops, 1 on each side**









**ORIS**  
ACPS

**HELPLINE**



[www.oris-automotive.com/en/acps-automotive-aftermarket-worldwide](http://www.oris-automotive.com/en/acps-automotive-aftermarket-worldwide)

**ORIS**  
ACPS