



HITCH, 2" Receiver, Subaru Legacy and Outback INSTALLATION INSTRUCTIONS

READ ALL WARNINGS AND INSTRUCTIONS BEFORE INSTALLATION

⚠ WARNING: The manufacturer of your vehicle may specify towing capacities lower than the capacities noted below. Never exceed the vehicle manufacturer's recommended towing capacity. Consult your vehicle's owner's manual for the manufacturer's recommended towing capacity for your specific vehicle.

NOTICE:

- Always use proper tools and safety equipment to ensure a safe and quality installation.
- Inspection of the trailer hitch should be performed before and after each use to ensure all mounting hardware is tight and related hitch components are secure.

⚠ WARNING: Before you begin installation, read all instructions thoroughly.

⚠ WARNING: Safety glasses should be worn at all times while installing this product.

⚠ WARNING: Failure to adhere to exact torque specifications when securing hardware during the installation process can result in damage to the product or your vehicle. This will void the hitch warranty.

LEVEL OF DIFFICULTY: EASY

Installation difficulty levels are based on the time and effort required. They will vary depending on the installer's expertise. Vehicle condition could be a factor in the level of difficulty for a proper installation.

WEIGHT CARRYING CAPACITY	
Gross Trailer Weight (GTWR)	4,500 LBS
Tongue Weight (TW)	675 LBS

WEIGHT DISTRIBUTING CAPACITY
THIS HITCH IS NOT RATED FOR USE AS A WEIGHT DISTRIBUTING HITCH.

TOOLS REQUIRED			
SAFETY GLASSES	RATCHET	10mm SOCKET	17mm SOCKET
FLATHEAD SCREWDRIVER	AVIATION SHEARS	8" EXTENSION	TORQUE WRENCH

INSTALLATION:

1. Lower the exhaust by detaching the two rear most exhaust hangers using a pry bar or exhaust hanger removal tool. Ensure that the exhaust is supported prior to removing the hangers to prevent damage.
2. Remove the heat shield by removing the four M6 hex head screws with the 10mm socket and ratchet. Dual exhaust vehicles will have two heat shields, both requiring removal.
3. Locate the four mounting holes as well as the hardware access holes on the underside of the vehicle's frame rails and remove the rubber plugs. Fishwire a 7/16" carriage bolt (**ITEM 1**) and a rectangular washer (**ITEM 2**) into each mounting hole, leaving the fishwires attached. See **FIG. 1** for standard fishwire technique.
4. Lift hitch into position with the flat washers (**ITEM 3**) taped in their correct locations on the top surface of the hitch's mounting flanges. As the hitch is lifted, feed the four fishwires and then the 7/16" carriage bolts through their respective mounting holes while also guiding the exhaust hanger pins through their respective slots.

CONTINUED NEXT PAGE

5. Thread a 7/16" serrated flange nut (**ITEM 4**) onto each protruding carriage bolt after removing the fishwire from the fastener. Care must be taken when removing the fishwire to prevent the fastener from coming out of position and being pushed inside the frame rail.

6. Torque all 7/16" fasteners to 70 ft-lb with the torque wrench and 17mm socket.

7. Trim heat shield(s) to create a 1-1/2" diameter clearance hole for the forward hitch fastener(s) and reinstall with the original vehicle hardware removed in step 2. The clearance hole should be approximately 2-3/4" aft of the forward-most heat shield fastener. See **FIG. 2** for trimming illustration.

8. Lift the exhaust back into its correct position and reattach the two rear-most exhaust hangers.

ITEM	DESCRIPTION	QTY
1	7/16 Carriage Bolt	4
2	Square Hole Rectangular Washer	4
3	7/16" Flat Washer	2
4	7/16" Serrated Flange Nut	4
-	7/16" Fishwire	4

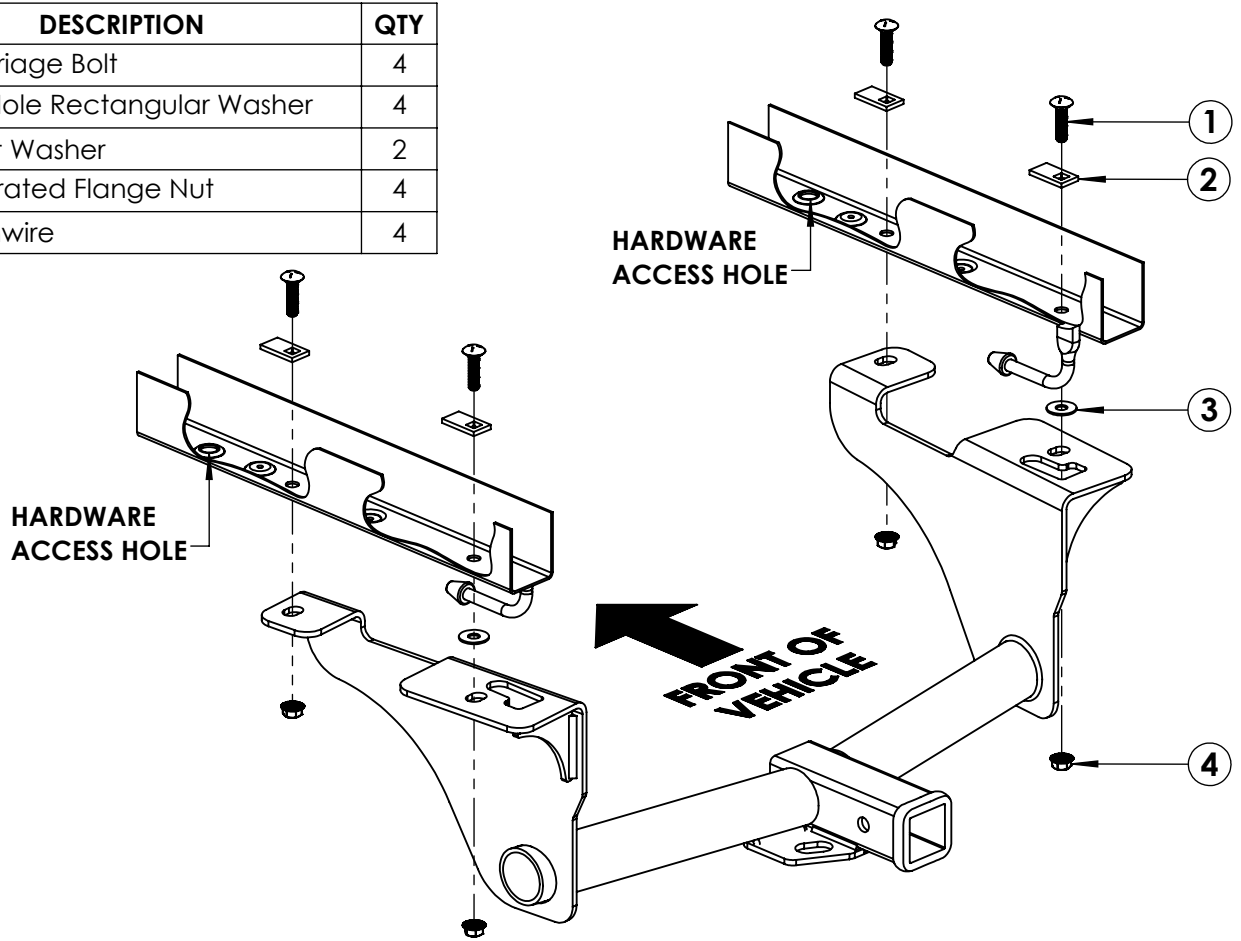

FIG. 1
STANDARD
FISHWIRE
TECHNIQUE

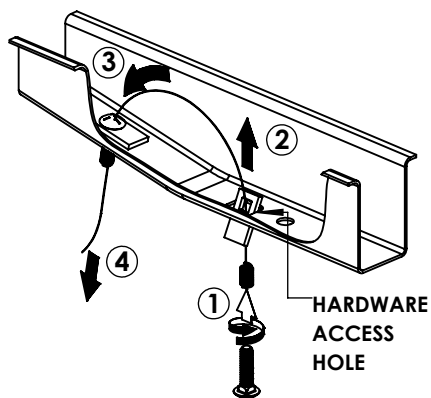

FIG. 2
HEAT SHIELD
TRIMMING

