



HITCH, 2" Receiver, Ford Edge INSTALLATION INSTRUCTIONS

READ ALL WARNINGS AND INSTRUCTIONS THOROUGHLY BEFORE INSTALLATION

⚠ WARNING: The manufacturer of your vehicle may specify towing capacities lower than the capacities noted below. Never exceed the vehicle manufacturer's recommended towing capacity. Consult your vehicle's owner's manual for the manufacturer's recommended towing capacity for your specific vehicle.

⚠ WARNING: Failure to adhere to the exact torque specifications noted in these installation instructions can result in property damage and/or bodily injury. Failure to follow all specifications and instructions will void the hitch warranty.

NOTICE:

Always use proper tools and safety equipment to ensure a safe and quality installation. Inspection of the trailer hitch should be performed before and after each use to ensure all mounting hardware is tight and related hitch components are secure.

LEVEL OF DIFFICULTY: Moderate

The installation of this hitch requires fishwiring hardware into location and trimming of underbody panels. Installation difficulty levels are based on the time and effort required. They will vary depending on the installer's expertise. Vehicle condition could be a factor in the level of difficulty for a proper installation.

WEIGHT CARRYING CAPACITY	
Gross Trailer Weight (GTWR)	4,000 LBS
Tongue Weight (TW)	600 LBS

WEIGHT DISTRIBUTING CAPACITY
THIS HITCH IS NOT RATED FOR USE AS A WEIGHT DISTRIBUTING HITCH.

TOOLS REQUIRED			
SAFETY GLASSES	RATCHET	5.5mm SOCKET	10mm SOCKET
3/4" SOCKET	T20 TORX BIT	TORQUE WRENCH	AVIATION SHEARS

INSTALLATION:

1. Remove the side underbody panels behind both rear wheels using the 5.5mm socket to remove the two outboard fasteners and the 10mm socket for the two inboard fasteners; four fasteners total per side.
2. Trim the side underbody panels as shown in **FIG. 1**. Set panels and fasteners aside for reinstallation.
3. Lower the exhaust by removing the two rear most rubber exhaust hangers from their respective pins on either side of the muffler. SPORT models will require the removal of the exhaust tips using the 5.5mm socket and the T20 Torx bit prior to lowering the exhaust. Ensure that the exhaust is supported before removing any of the hangers to prevent damage to the exhaust system.
4. Remove the two outboard fasteners of the center underbody panel using the 10mm socket and ratchet. Trim the outboard mounting tabs of the center underbody panel with the panel in place on the vehicle to provide clearance for the rear most hardware mounting holes.
5. Locate the hardware access holes at the rear of the frame rails, accessible though the outboard ends of the bumper reinforcement. Also, locate the two fastener holes on the bottom surface of the frame rail as well as the single fastener hole on the outside face of the frame rail on both sides of the vehicle. Using the standard fishwire technique (**FIG. 2**), install a 1/2-13 UNC carriage bolt (**ITEM 1**) and square hole spacer (**ITEM 2**) into each of the six fastener holes. Leave fishwires secured to the carriage bolts.

continued on next page

continued from previous page

6. Lift hitch into position, over the exhaust, while feeding the fishwires and then the fasteners through their respective mounting holes. Remove the fishwires and thread a 1/2-13 UNC serrated flange hex nut (**ITEM 3**) onto each of the six protruding screws being careful not to lose the carriage bolts inside the frame rails.

7. Secure the six serrated flange nuts (ITEM3) using the 3/4" socket and ratchet. **Torque all six 1/2" fasteners to 110 ft-lb.**

8. Reinstall the two side underbody panels using the fasteners that were removed and set aside. Reinstall the two outboard fasteners of the center underbody panel to secure it to the underside of the vehicle.

9. Raise the exhaust back into its correct position and secure by reattaching the two rubber exhaust hangers on either side of the muffler. Be sure to remove whatever means were used to support the exhaust while it was lowered for hitch installation.

ITEM	DESCRIPTION	QTY
1	CARRIAGE BOLT, 1/2-13 UNC x 1-1/2	6
2	SQUARE HOLE SPACER, 1/2"	6
3	NUT, SERRATED FLANGE, 1/2-13 UNC	6
-	FISHWIRE, 1/2"	4

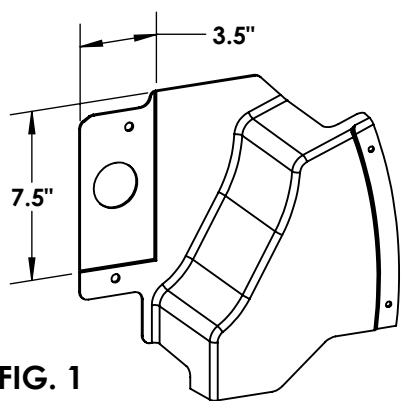

FIG. 1
SIDE UNDERBODY PANEL
TRIMMING ILLUSTRATION
PASSENGER SIDE SHOWN

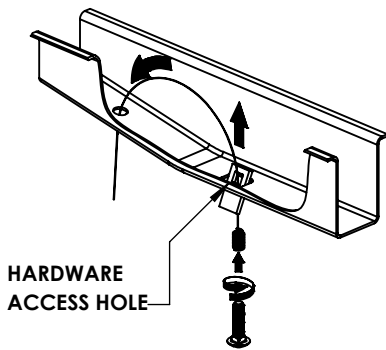
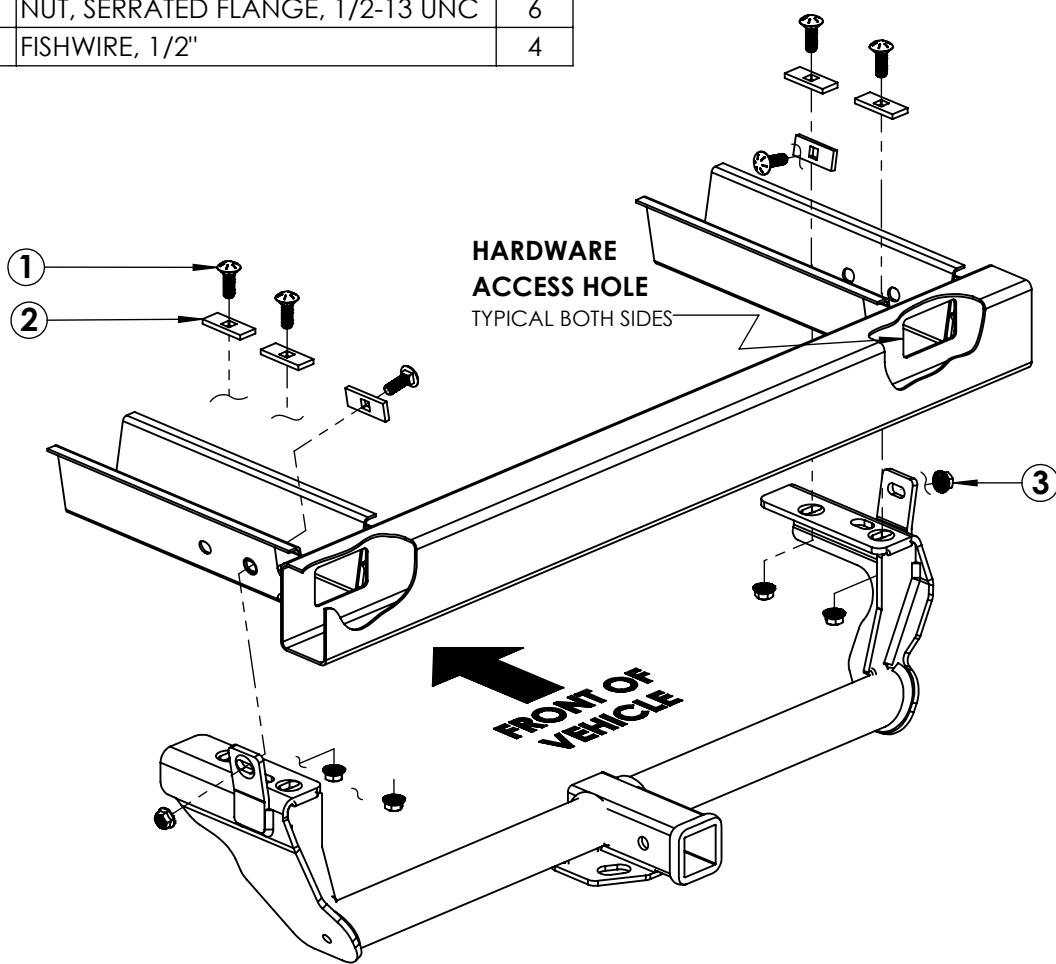

FIG. 2
STANDARD FISHWIRE
TECHNIQUE

